

MATRIARCH

EQUIPMENT

ULTeco6

4WD Sugarcane Slew Loader

DURABILITY // PRODUCTIVITY // EFFICIENCY // LOW COST PER TON

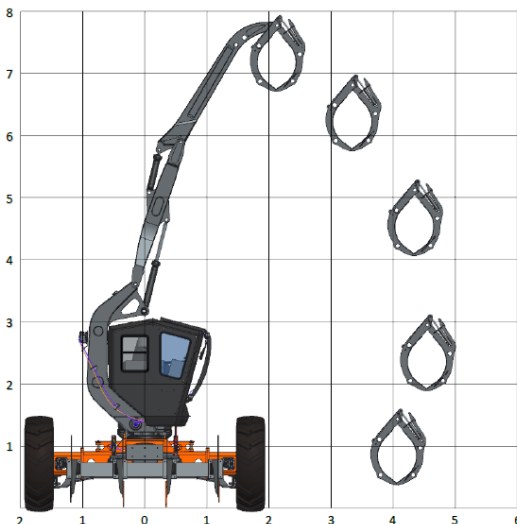

FRONT VIEW

SIDE VIEW

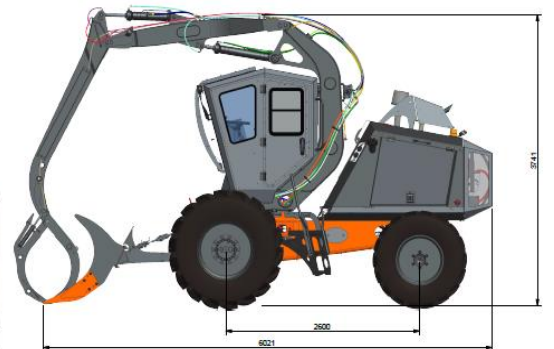

ENGINE	
JCB Diesel Max 444 T2 NA 63 kW (84 HP) @ 2200 RPM	
Mechanical Engine - Equipped with a dry element filtration system with secondary safety element and filter mounted visual warning indicator - Precleaner, Primary Filter and Secondary Safety Element.	
Fuel Tank Capacity - 100 litres	
DRIVE SYSTEM	
Hydrostatic Drive System	
Two Speed	
Two Wheel Drive (<i>Optional Four Wheel Drive</i>)	
Maximum Speed of 25 KPH (15.6 MPH)	
AXLES AND TYRES	
Rigid Front Axle	
Oscillating Rear Axle with Steering Hubs	
Rear Axle Steer	
Tyre Size - Front	18.4 - 30
Tyre Size - Rear	14.9 - 24
BOOM AND GRAPPLE	
Double Acting - Boom & Dipper Arm	
Boom Slew Travel - 185 degree	
Wide Grapple with Tilting Function	
Grapple Capacity - 0.38 sqm	
OPTIONAL PUSH-PILER & GRAPPLE	
Push Piler - Infinitely Adjustable Tine Positioning, Hydraulic Height Adjustment	
Grapple Arrangement - Dangle Type, Fore/Aft Pivoting	
HYDRAULIC SYSTEM	
Tandem Gear Pump	
Split Control Valve - Optimal Flow Sharing	
Low Effort Pilot Operated Controls	
Hydraulic Tank Capacity - 100 litres	
ELECTRICAL SYSTEM	
Single 12 Volt Battery	
Alternator - 14 volt 95 amp	
Worklights, Reverse Alarm & Hooter	
OPERATOR STATION	
Superior Visibility - Operator Always Faces the Load	
Machine Systems Monitoring and Warning Indicators	
Ergonomic Operator Controls - Joystick Type	
Glazed Operator Cab	
Air-Conditioner, non HVAC	
BRAKES	
Hydrostatic Dynamic Braking System	
Spring Applied, Hydraulic Release Park Brake - Two Drive Wheels	
WEIGHTS AND DIMENSIONS	
Option 1	2.10m
Option 2	2.50m
Option 3	3.00m
Option 4	3.40m
Operating Weight	6450 kg

